

100 Gigabit Ethernet (100 GbE)

Advanced Serial 100Gb/s Transmission Technology for Next Generation Optical Transport Networks

BELL LABS Research Project

Context

Modern telecommunication networks need to be built with enormous traffic growth in mind. For example, today some internet exchange nodes have annual growth rates of more than 200% due to dramatic increases in users coupled with the needs of enriched data and broadband video services.

Accommodation of the global explosion in traffic (Figure 1) can only be assured by implementation of the most advanced high capacity optical metro/core transport network technologies. Soon networks based on next generation 40/100 Gigabit Ethernet (GbE) transport technologies will predominate. They will be based on standards currently under preparation by several standards organisations (e.g. IEEE, ITU-T).

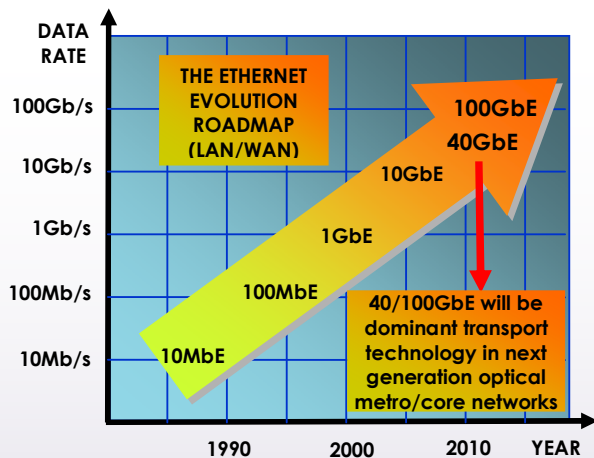

Figure 1: Technology roadmap of optical transport networks. 40/100GbE will be dominant technology within the next decade.

Alcatel-Lucent's concepts and real-time trials demonstrate 100GbE's graceful introduction and evolution to meet operators' future needs.

Challenges

To get from here to there, several challenges associated with development and operation of ultra-high speed components and systems for serial 100 Gbit/s optical transmission must be overcome:

- Stronger transmission signal impairments associated with the upgrade of data rates, due to chromatic dispersion (CD) and

polarization mode dispersion (PMD), must be compensated or mitigated efficiently.

- Spectral efficiency must increase, enabling 100Gb/s transmissions over existing 10/40G DWDM systems (50/100GHz channel spacing).
- Complex integrated circuits for digital signal processing (DSP) and new very high-speed components have to be developed using state-of-the-art electronics and photonics.

Innovation

Alcatel-Lucent has developed 100 GbE concepts, shown prototypes and done field trials demonstrating its expertise in addressing future requirements.

Dispersion tolerant serial Nx100Gb/s DWDM transmission with high spectral efficiency

Figure 2 is a schematic of how high capacity Nx100Gb/s optical transmission is feasible over long-haul fiber links without dispersion compensation units (DCU) using conventional 10Gb/s DWDM platforms with narrow channel spacing (50GHz) corresponding to a spectral efficiency of 2bit/s/Hz.

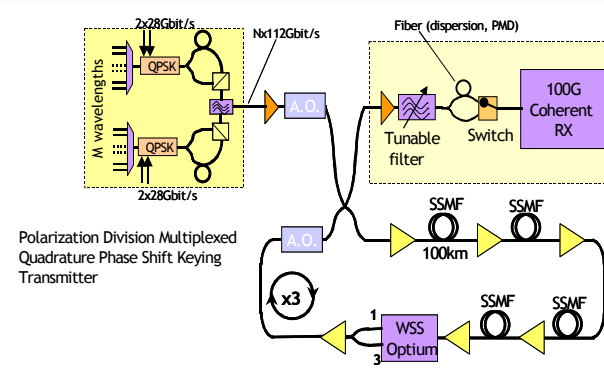

Figure 2: Nx100Gb/s Coherent PDM-QPSK DWDM transmission over 1200km laboratory fiber link.

Verizon 100G field trial with live traffic

Alcatel-Lucent, in a real-time field trial with Verizon (Figure 3), proved a 100Gb/s channel carrying a HDTV video signal can transmit parallel to existing live traffic 10Gb/s DWDM channels.

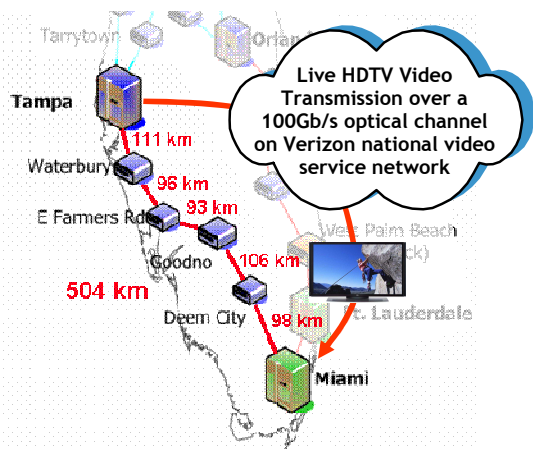

Figure 3: Verizon 100Gb/s transmission trial over 500 km link. In a trial in Germany (Figure 4) dense-wavelength-division-multiplexed(DWDM) 100Gb/s channels were sent efficiently over long-haul fiber infrastructure exhibiting typical field transmission characteristics.

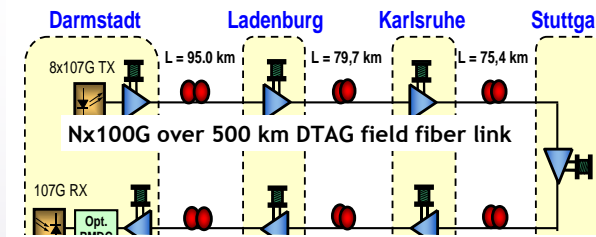

Figure 4: 8x100Gb/s NRZ-VSB DWDM transmission over 500km installed field fiber with typical field transmission characteristics.

Scenario

A number of new broadband applications—HDTV distribution, video downloading, data center content delivery, etc.—are feeding continued traffic growth in metro/core networks. Figure 5 shows actual (2008) composition of network traffic. It illustrates that broadband/video services (e.g. video distribution, online video recording, YouTube, iPlayer...) already dominate network traffic. Important future traffic drivers will emerge from advanced applications like telepresence and sensor networks. In other words, we are only at the beginning of the expected explosion in both underlying traffic and the need for more bandwidth for sophisticated applications.

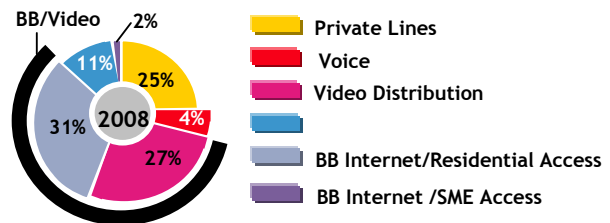

Figure 5: Actual composition of network traffic (2008)

Regardless of what the future may bring in terms of new applications, the novel 100GbE-based transport technology represents an important step towards insuring the capacity and flexibility will be there to accommodate overall traffic growth requirements.

The proof can already be seen in the pioneering results on advanced 100Gb/s serial transmission achieved by Bell Labs. This include records in high capacity and spectral efficiency of Nx100Gb/s DWDM transmission, and first real-time 100Gb/s field transmission trials with live traffic.

BENEFIT: Bell Lab's expertise in 100Gb/s assures operators are ready for the coming explosion in bandwidth-hungry applications and services.

Contact:
Gustav.Veith@alcatel-lucent.com
Sebastien.Bigo@alcatel-lucent.com
winzler@alcatel-lucent.com
 Optical Networks Domain
 Alcatel-Lucent Bell Labs

Résumé:

Nous sommes à la veille d'une explosion des besoins en bande passante, du fait de l'augmentation au niveau mondial du nombre d'utilisateurs et du développement d'applications sophistiquées et riches en contenus. Les systèmes 100 GbE constitueront l'infrastructure dominante de prochaine génération qui sera déployée pour faire face à cet accroissement. Les Bell Labs ont mis au point des concepts et réalisé des essais en temps réel sur le terrain qui démontrent qu'ils disposent de solides compétences dans le domaine de la technologie 100 GbE. Grâce à ces compétences, ils sont en mesure de permettre aux opérateurs de se préparer efficacement afin de rester réactif, quelle que soit l'évolution future du haut débit.

